

Closer to Real, **ROBOTIS**

Dynamixel **RX-28**



Contents

1. Summary	
1-1. Overview and Characteristics of RX-28	Page 2
1-2. Main Specifications	Page 3
2. Dynamixel Operation	
2-1. Mechanical Assembly	Page 4
2-2. Connector Assembly	Page 5
2-3. Dynamixel Wiring	Page 6
3. Communication Protocol	
3-1. Communication Overview	Page 9
3-2. Instruction Packet	Page 10
3-3. Status Packet	Page 10
3-4. Control Table	Page 12
4. Instruction Set and Examples	
4-1. WRITE_DATA	Page 19
4-2. READ_DATA	Page 20
4-3. REG WRITE and ACTION	Page 21
4-4. PING	Page 22
4-5. RESET	Page 22
4-6. SYNCWRITE	Page 23
5. Example	Page 25
Appendix	Page 31

1. Dynamixel RX-28

1-1. Overview and Characteristics of RX-28

Dynamixel RX-28	The Dynamixel series robot actuator is a smart, modular actuator that incorporates a gear reducer, a precision DC motor and a control circuitry with networking functionality, all in a single package. Despite its compact size, it can produce high torque and is made with high quality materials to provide the necessary strength and structural resilience to withstand large external forces. It also has the ability to detect and act upon internal conditions such as changes in internal temperature or supply voltage. The Dynamixel RX-28 has many advantages over similar products.
Precision Control	Position and speed can be controlled with a resolution of 1024 steps.
Compliance Driving	The degree of compliance can be adjusted and specified in controlling position.
Feedback	Feedback for angular position, angular velocity, and load torque are available.
Alarm System	The Dynamixel series robot actuator can alert the user when parameters deviate from user defined ranges (e.g. internal temperature, torque, voltage, etc) and can also handle the problem automatically (e.g. torque off)
Communication	Wiring is easy with daisy chain connection, and it support communication speeds up to 1M BPS.
Distributed Control	Position, velocity, compliance, and torque can be set with a single command packet, thus enabling the main processor to control many Dynamixel units even with very few resources.
Engineering Plastic	The main body of the unit is made with high quality engineering plastic which enables it to handle high torque loads.
Axis Bearing	A bearing is used at the final axis to ensure no efficiency degradation with high external loads.
Status LED	The LED can indicate the error status to the user.
Frames	A hinge frame and a side mount frame are supported by option.

1-2. Main Specifications

	RX-28	
Weight (g)	72	
Gear Reduction Ratio	1/193	
Input Voltage (V)	at 12V	at 16V
Final Max Holding Torque(kgf.cm)	28.3	37.7
Sec/60degree	0.167	0.126

Resolution	0.3°
Operating Angle	300°, Endless Turn
Voltage	12V~16V (Recommended voltage: 14.4V)
Max. Current	1200mA
Operate Temperature	-5℃ ~ +85℃
Command Signal	Digital Packet
Protocol Type	RS485 Asynchronous Serial Communication (8bit,1stop,No Parity)
Link (Physical)	RS485 Multi Drop Bus
ID	254 ID (0~253)
Communication Speed	7343bps ~ 1 Mbps
Feedback	Position, Temperature, Load, Input Voltage, etc.
Material	Full Metal Gear, Engineering Plastic
Motor	Maxon RE-MAX

2. Dynamixel Operation

2-1. Mechanical Assembly

Option Frames

OF-28B

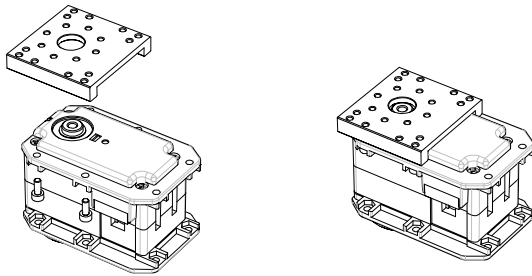

OF-28S

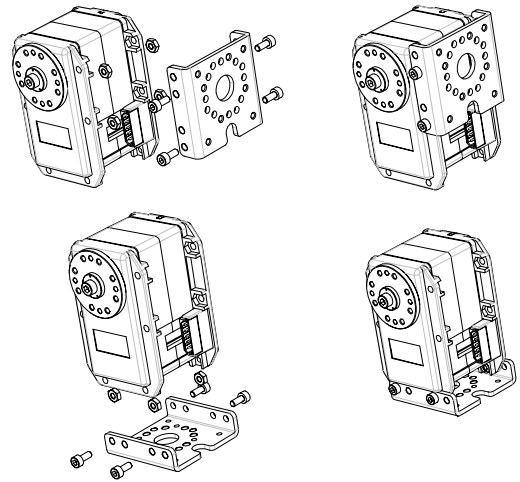

RXOF-28H

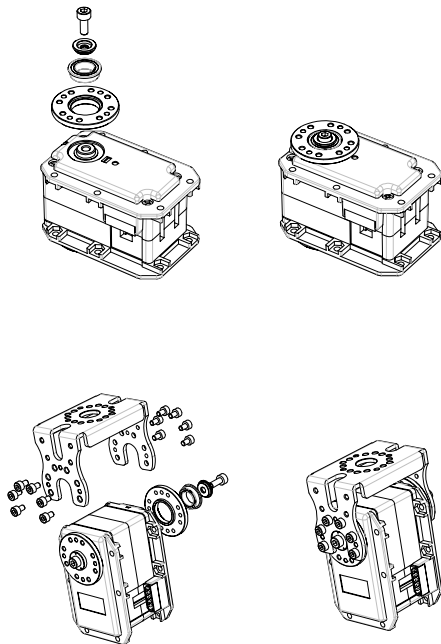

Horn-28T

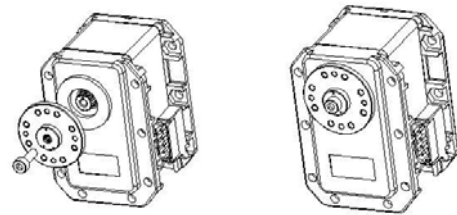

Assembly

Sample assembly using option frames.

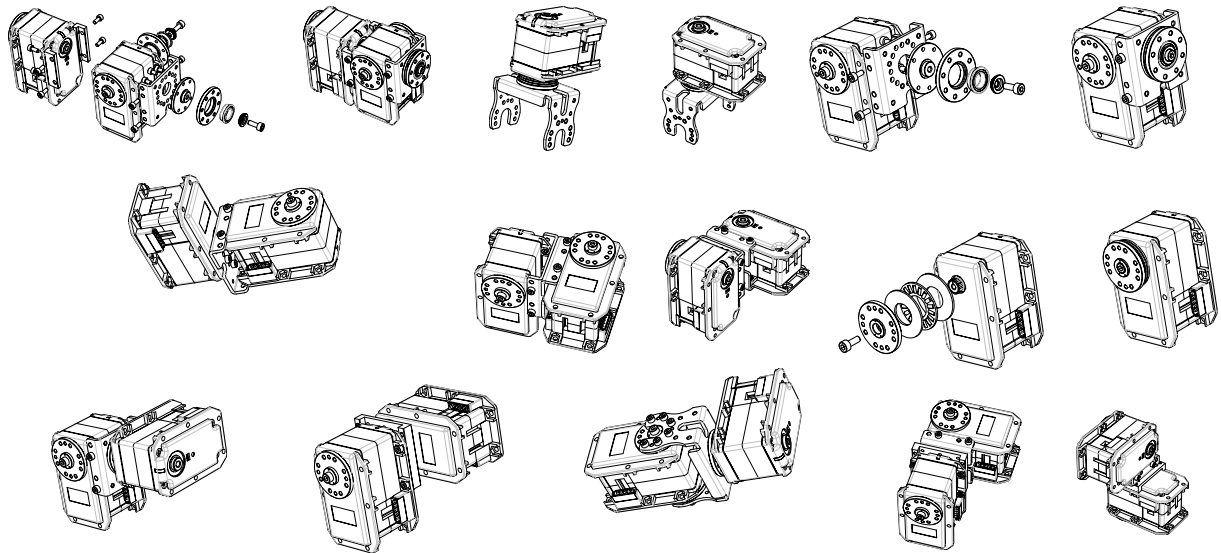

2-2 . Connector Assembly

Assemble the connectors as shown below. Attach the wires to the terminals using the correct crimping tool. If you do not have access to a crimping tool, solder the terminals to the wires to ensure that they do not become loose during operation.

1) Striping



2) Inserting



4) Formed Wire



3) Forming



5) Assembling



6) Complete



2-3. Dynamixel Wiring

Pin Assignment The connector pin assignments are as the following. The two connectors on the Dynamixel are connected pin to pin, thus the RX-28 can be operated with only one connector attached.

(Note : The pin number of connector's edge cut side is PIN1)

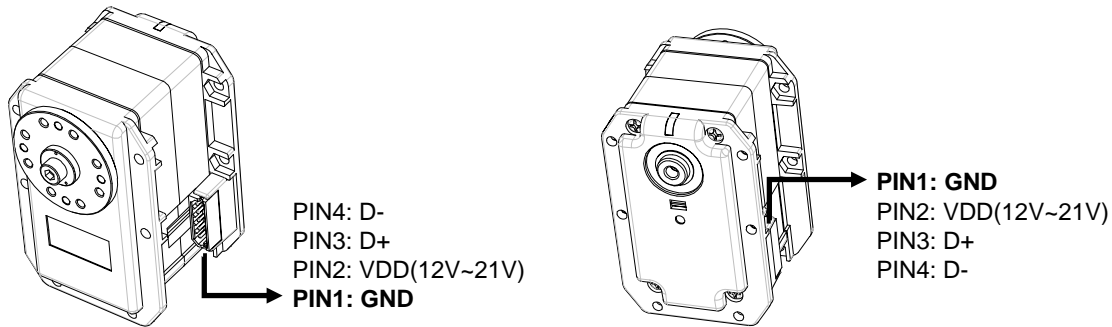

Wiring Connect the RX-28 actuators pin to pin as shown below. Many RX-28 actuators can be controlled with a single bus in this manner.

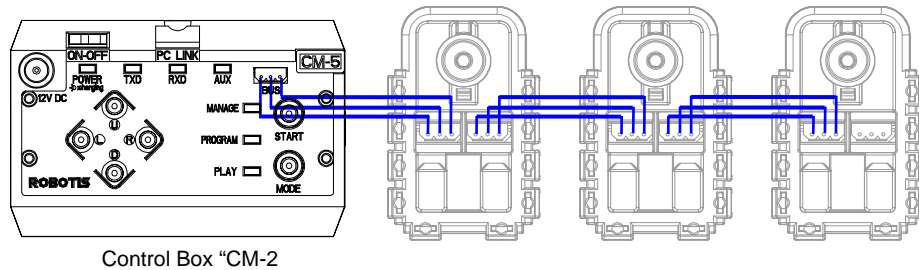

Main Controller To operate the Dynamixel actuators, the main controller must support RS485 UART. A proprietary controller can be used, but the use of the Dynamixel controller CM-2 PLUS is recommended.

Connection to UART To control the Dynamixel actuators, the main controller needs to convert its UART signals to the RS485 type. The recommended circuit diagram for this is shown below.\

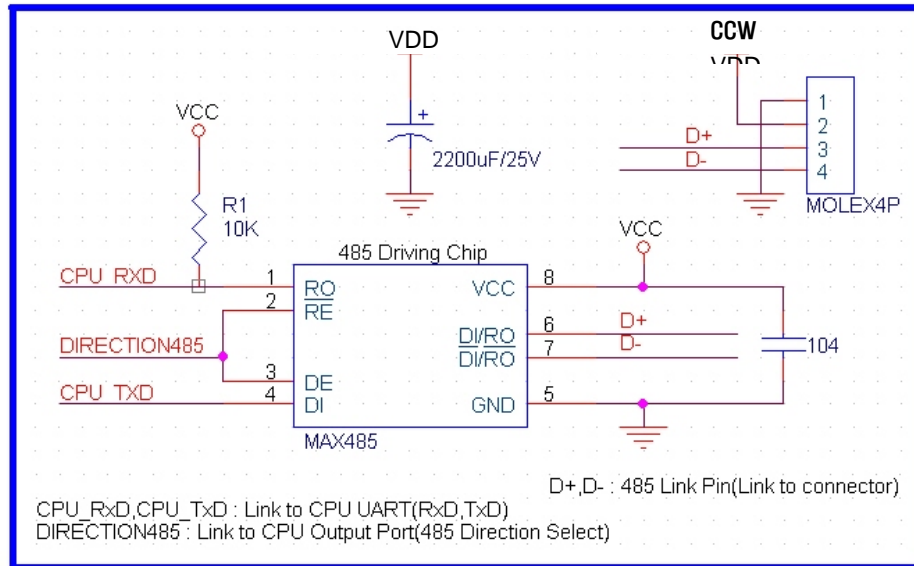

Application Example for RS485 Link

The power is supplied to the Dynamixel actuator from the main controller through Pin 1 and Pin 2 of the Molex3P connector. (The circuit shown above is presented only to explain the use of RS485 UART. The CM-2 PLUS controller already has the above circuitry built in, thus the Dynamixel actuators can be directly connected to it)

The direction of data signals on the TTL level TxD and RxD depends on the DIRECTION485 level as the following.

- When the DIRECTION485 level is High: the signal TxD is output as D+, D-
- When the DIRECTION485 level is Low: the signal D+, D- is input as RxD

RS485 UART

A multi-drop method of connecting multiple Dynamixel actuators to a single node is possible by using the RS485 UART. Thus a protocol that does not allow multiple transmissions at the same time should be maintained when controlling the Dynamixel actuators.



[Multi Drop Link]

Caution

Please ensure that the pin assignments are correct when connecting the Dynamixel actuators. Check the current consumption when powering on. The current consumption of a single Dynamixel actuator unit in standby mode should be no larger than 50mA

Connection Status Verification

When power is applied to the Dynamixel actuator, the LED blinks twice to confirm its connection.

Inspection

If the above operation was not successful, then check the connector pin assignment and the voltage/current limit of the power supply.

3. Communication Protocol

3-1. Communication Overview

Packet

The main controller communicates with the Dynamixel units by sending and receiving data packets. There are two types of packets; the "Instruction Packet" (sent from the main controller to the Dynamixel actuators) and the "Status Packet" (sent from the Dynamixel actuators to the main controller.)

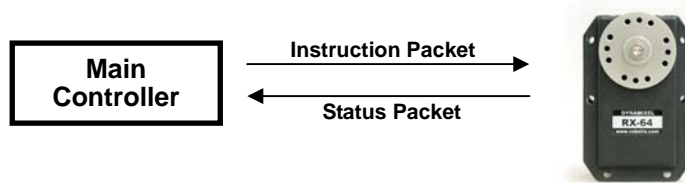

Communication

For the system connection below, if the main controller sends an instruction packet with the ID set to N, only the Dynamixel unit with this ID value will return its respective status packet and perform the required instruction.

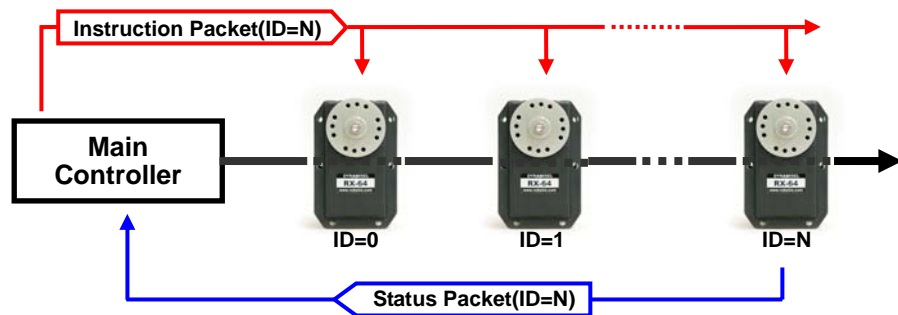

Unique ID

If multiple Dynamixel units have the same ID value, multiple packets sent simultaneously collide, resulting in communication problems. Thus, it is imperative that no Dynamixel units share the same ID in a network node.

Protocol

The Dynamixel actuators communicate through asynchronous serial communication with 8 bit, 1 stop bit and no parity.

3-2. Instruction Packet

The Instruction Packet is the packet sent by the main controller to the Dynamixel units to send commands. The structure of the Instruction Packet is as the following.

Instruction Packet 0XFF 0XFF ID LENGTH INSTRUCTION PARAMETER1 ... PARAMETER N CHECK SUM

The meanings of each packet byte definition are as the following.

0XFF 0XFF

The two 0XFF bytes indicate the start of an incoming packet.

ID

The unique ID of a Dynamixel unit. There are 254 available ID values, ranging from 0X00 to 0XFD.

Broadcasting ID

ID 0XFE is the Broadcasting ID which indicates all of the connected Dynamixel units. Packets sent with this ID apply to all Dynamixel units on the network. Thus packets sent with a broadcasting ID will not return any status packets.

LENGTH

The length of the packet where its value is "Number of parameters (N) + 2"

INSTRUCTION

The instruction for the Dynamixel actuator to perform.

PARAMETER0...N

Used if there is additional information needed to be sent other than the instruction itself.

CHECK SUM

The computation method for the 'Check Sum' is as the following.

Check Sum = $\sim (ID + Length + Instruction + Parameter1 + \dots + Parameter N)$

If the calculated value is larger than 255, the lower byte is defined as the checksum value.

\sim represents the NOT logic operation.

3-3. Status Packet(Return Packet)

The Status Packet is the response packet from the Dynamixel units to the Main Controller after receiving an instruction packet. The structure of the status packet is as the following.

0XFF 0XFF ID LENGTH ERROR PARAMETER1 PARAMETER2 ... PARAMETER N CHECK SUM

The meanings of each packet byte definition are as the following.

0XFF 0XFF

The two 0XFF bytes indicate the start of the packet.

ID

The unique ID of the Dynamixel unit returning the packet. The initial value is set to 1.

LENGTH

The length of the packet where its value is "Number of parameters (N) + 2"

ERROR

The byte representing errors sent from the Dynamixel unit. The meaning of each bit is as the following.

Bit	Name	Details
Bit 7	0	-
Bit 6	Instruction Error	Set to 1 if an undefined instruction is sent or an action instruction is sent without a Reg_Write instruction.
Bit 5	Overload Error	Set to 1 if the specified maximum torque can't control the applied load.
Bit 4	Checksum Error	Set to 1 if the checksum of the instruction packet is incorrect.
Bit 3	Range Error	Set to 1 if the instruction sent is out of the defined range.
Bit 2	Overheating Error	Set to 1 if the internal temperature of the Dynamixel unit is above the operating temperature range as defined in the control table.
Bit 1	Angle Limit Error	Set as 1 if the Goal Position is set outside of the range between CW Angle Limit and CCW Angle Limit.
Bit 0	Input Voltage Error	Set to 1 if the voltage is out of the operating voltage range as defined in the control table.

PARAMETER0...N

Used if additional information is needed.

CHECK SUM

The computation method for the 'Check Sum' is as the following.

$$\text{Check Sum} = \sim (\text{ID} + \text{Length} + \text{Instruction} + \text{Parameter1} + \dots + \text{Parameter N})$$

If the calculated value is larger than 255, the lower byte is defined as the checksum value. \sim represents the NOT logic operation.

3-4. Control
Table

Address	Item	Access	Initial Value
0(0X00)	Model Number(L)	RD	28(0x1C)
1(0X01)	Model Number(H)	RD	0(0x00)
2(0X02)	Version of Firmware	RD	?
3(0X03)	ID	RD,WR	1(0x01)
4(0X04)	Baud Rate	RD,WR	34(0x22)
5(0X05)	Return Delay Time	RD,WR	250(0xFA)
6(0X06)	CW Angle Limit(L)	RD,WR	0(0x00)
7(0X07)	CW Angle Limit(H)	RD,WR	0(0x00)
8(0X08)	CCW Angle Limit(L)	RD,WR	255(0xFF)
9(0X09)	CCW Angle Limit(H)	RD,WR	3(0x03)
10(0x0A)	(Reserved)	-	0(0x00)
11(0X0B)	the Highest Limit Temperature	RD,WR	85(0x55)
12(0X0C)	the Lowest Limit Voltage	RD,WR	60(0X3C)
13(0X0D)	the Highest Limit Voltage	RD,WR	240(0xF0)
14(0X0E)	Max Torque(L)	RD,WR	255(0xFF)
15(0X0F)	Max Torque(H)	RD,WR	3(0x03)
16(0X10)	Status Return Level	RD,WR	2(0x02)
17(0X11)	Alarm LED	RD,WR	4(0x04)
18(0X12)	Alarm Shutdown	RD,WR	4(0x04)
19(0X13)	(Reserved)	RD,WR	0(0x00)
20(0X14)	Down Calibration(L)	RD	?
21(0X15)	Down Calibration(H)	RD	?
22(0X16)	Up Calibration(L)	RD	?
23(0X17)	Up Calibration(H)	RD	?
24(0X18)	Torque Enable	RD,WR	0(0x00)
25(0X19)	LED	RD,WR	0(0x00)
26(0X1A)	CW Compliance Margin	RD,WR	0(0x00)
27(0X1B)	CCW Compliance Margin	RD,WR	0(0x00)
28(0X1C)	CW Compliance Slope	RD,WR	32(0x20)
29(0X1D)	CCW Compliance Slope	RD,WR	32(0x20)
30(0X1E)	Goal Position(L)	RD,WR	[Addr36]value
31(0X1F)	Goal Position(H)	RD,WR	[Addr37]value
32(0X20)	Moving Speed(L)	RD,WR	0
33(0X21)	Moving Speed(H)	RD,WR	0
34(0X22)	Torque Limit(L)	RD,WR	[Addr14] value
35(0X23)	Torque Limit(H)	RD,WR	[Addr15] value
36(0X24)	Present Position(L)	RD	?
37(0X25)	Present Position(H)	RD	?
38(0X26)	Present Speed(L)	RD	?
39(0X27)	Present Speed(H)	RD	?
40(0X28)	Present Load(L)	RD	?
41(0X29)	Present Load(H)	RD	?
42(0X2A)	Present Voltage	RD	?
43(0X2B)	Present Temperature	RD	?
44(0X2C)	Registered Instruction	RD,WR	0(0x00)
45(0X2D)	(Reserved)	-	0(0x00)
46(0x2E)	Moving	RD	0(0x00)
47(0x2F)	Lock	RD,WR	0(0x00)
48(0x30)	Punch(L)	RD,WR	32(0x20)
49(0x31)	Punch(H)	RD,WR	0(0x00)

Control Table The Control Table contains information on the status and operation of the Dynamixel actuator. The Dynamixel actuator is operated by writing values to its control table and its status is checked by reading values off its control table.

RAM and EEPROM The data values for the RAM area will be set to the default initial values whenever the power is turned on. However, the data values for the EEPROM area are non-volatile and will still remain even after the power is turned off.

Initial Value The Initial Value column on the right side of the control table shows the Factory Default Values for the case of EEPROM area data, and shows the initial value when the power is turned on for the case of RAM area data.

The following explains the meaning of data stored in each of the addresses in the control table.

Address 0x00,0x01 **Model Number.** For RX-28, this value is 0X001C (28).

Address 0x02 **Firmware Version.**

Address 0x03 **ID.** The unique ID number assigned to each Dynamixel actuators for identifying them. Different IDs are required for each Dynamixel actuators that are on the same network.

Address 0x04 **Baud Rate.** Determines the communication speed. The computation is done by the following formula.

$$\text{Speed (BPS)} = 2000000 / (\text{Address4} + 1)$$

Data Value for each Major Baud Rate

Adress4	Hex	Set BPS	Goal BPS	Error
1	0X01	1000000.0	1000000.0	0.000%
3	0X03	500000.0	500000.0	0.000%
4	0X04	400000.0	400000.0	0.000%
7	0X07	250000.0	250000.0	0.000%
9	0X09	200000.0	200000.0	0.000%
16	0X10	117647.1	115200.0	-2.124%
34	0X22	57142.9	57600.0	0.794%
103	0X67	19230.8	19200.0	-0.160%
207	0XCF	9615.4	9600.0	-0.160%

Note A maximum Baud Rate error of 3% is within the tolerance of UART communication.

Caution The initial value of Baudrate is set to 34(57600bps)

Address 0x05 **Return Delay Time.** The time it takes for the Status Packet to return after the Instruction Packet is sent. The delay time is given by $2\mu\text{Sec} * \text{Address5 value}$.

Address 0x06,0x07,0x08,0x09

Operating Angle Limit. Sets the Dynamixel actuator's operating angle range. The Goal Position needs to be within the range of: $\text{CW Angle Limit} \leq \text{Goal Position} \leq \text{CCW Angle Limit}$. An Angle Limit Error will occur if the Goal Position is set outside this range set by the operating angle limits.

Address 0x0B

the Highest Limit Temperature. The upper limit of the Dynamixel actuator's operating temperature. If the internal temperature of the Dynamixel actuator gets higher than this value, the Over Heating Error Bit (Bit 2 of the Status Packet) will return the value 1, and an alarm will be set by Address 17, 18. The values are in Degrees Celsius.

Address 0x0C,0x0D

the Lowest (Highest) Limit Voltage. The upper and lower limits of the Dynamixel actuator's operating voltage. If the present voltage (Address 42) is out of the specified range, a Voltage Range Error Bit (Bit 0 of the Status Packet) will return the value 1, and an alarm will be set by Address 17, 18. The values are 10 times the actual voltage value. For example, if the Address 12 value is 80, then the lower voltage limit is set to 8V.

Address 0x0E,0x0F, 0x22,0x23

Max Torque. The maximum torque output for the Dynamixel actuator. When this value is set to 0, the Dynamixel actuator enters the Free Run mode. There are two locations where this maximum torque limit is defined; in the EEPROM (Address 0x0E, 0x0F) and in the RAM (Address 0x22, 0x23). When the power is turned on, the maximum torque limit value defined in the EEPROM is copied to the location in the RAM. The torque of the Dynamixel actuator is limited by the values located in the RAM (Address 0x22, 0x23).

Address 0x10

Status Return Level. Determines whether the Dynamixel actuator will return a Status Packet after receiving an Instruction Packet.

Address16	Returning the Status Packet
0	Do not respond to any instructions
1	Respond only to READ_DATA instructions
2	Respond to all instructions

In the case of an instruction which uses the Broadcast ID (0XFE) the Status Packet will not be returned regardless of the Address 0x10 value.

Address 0X11

Alarm LED. If the corresponding Bit is set to 1, the LED blinks when an Error occurs.

Bit	Function
Bit 7	0
Bit 6	If set to 1, the LED blinks when an Instruction Error occurs
Bit 5	If set to 1, the LED blinks when an Overload Error occurs
Bit 4	If set to 1, the LED blinks when a Checksum Error occurs
Bit 3	If set to 1, the LED blinks when a Range Error occurs
Bit 2	If set to 1, the LED blinks when an Overheating Error occurs
Bit 1	If set to 1, the LED blinks when an Angle Limit Error occurs
Bit 0	If set to 1, the LED blinks when an Input Voltage Error occurs

This function operates following the “OR” logical operation of all bits. For example, if the value is set to 0X05, the LED will blink when an Input Voltage Error occurs or when an Overheating Error occurs. Upon returning to a normal condition from an error state, the LED stops blinking after 2 seconds.

Address 0X12

Alarm Shutdown. If the corresponding Bit is set to a 1, the Dynamixel actuator’s torque will be turned off when an error occurs.

Bit	Function
Bit 7	0
Bit 6	If set to 1, torque off when an Instruction Error occurs
Bit 5	If set to 1, torque off when an Overload Error occurs
Bit 4	If set to 1, torque off when a Checksum Error occurs
Bit 3	If set to 1, torque off when a Range Error occurs
Bit 2	If set to 1, torque off when an Overheating Error occurs
Bit 1	If set to 1, torque off when an Angle Limit Error occurs
Bit 0	If set to 1, torque off when an Input Voltage Error occurs

This function operates following the “OR” logical operation of all bits. However, unlike the Alarm LED, after returning to a normal condition, it maintains the torque off status. To recover, the Torque Enable (Address 0X18) needs to be reset to 1.

Address 0x14~0x17

Calibration. Data used for compensating for the differences between the potentiometers used in the Dynamixel units. The user cannot change this data.

The following (from Address 0x18) is in the RAM area.

Address 0x18 Torque Enable. When the power is first turned on, the Dynamixel actuator enters the Torque Free Run condition (zero torque). Setting the value in Address 0x18 to 1 enables the torque.

Address 0x19 LED. The LED turns on when set to 1 and turns off if set to 0.

Address 0x1A~0x1D Compliance Margin and Slope. The compliance of the Dynamixel actuator is defined by setting the compliance Margin and Slope. This feature can be utilized for absorbing shocks at the output shaft. The following graph shows how each compliance value (length of A, B, C & D) is defined by the Position Error and applied torque.

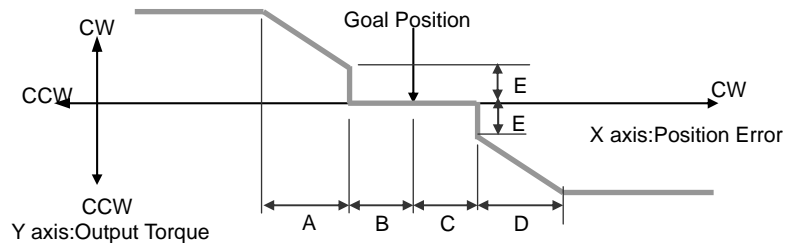

- A : CCW Compliance Slope(Address0x1D)
- B : CCW Compliance Margin(Address0x1B)
- C : CW Compliance Margin(Address0x1A)
- D : CW Compliance Slope (Address0x1C)
- E : Punch(Address0x30,31)

Address 0x1E,0x1F Goal Position Requested angular position for the Dynamixel actuator output to move to. Setting this value to 0x3ff moves the output shaft to the position at 300°.

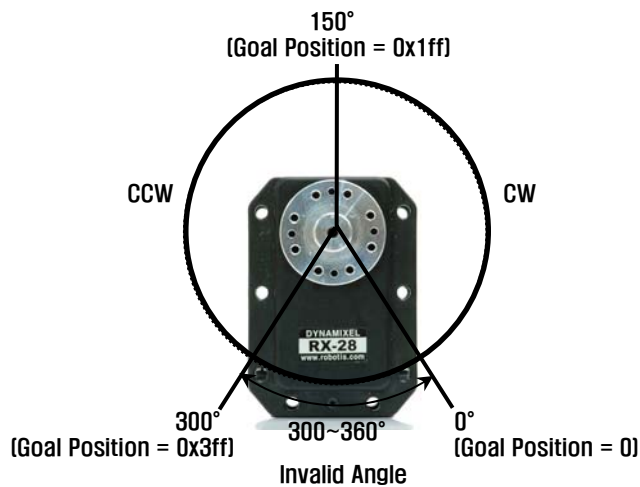

Address 0x20,0x21 **Moving Speed.** Sets the angular velocity of the output moving to the Goal Position. Setting this value to its maximum value of 0x3ff moves the output with the maximum angular velocity which depends on the level of power supplied and Dynamixel series. (The lowest velocity is when this value is set to 1. When set to 0, the velocity is the largest possible for the supplied voltage, e.g. no velocity control is applied.)

Address 0x24,0x25 **Present Position.** Current angular position of the Dynamixel actuator output.

Address 0x26,0x27 **Present Speed.** Current angular velocity of the Dynamixel actuator output.

Address 0x28,0x29 **Present Load.** The magnitude of the load on the operating Dynamixel actuator. Bit 10 is the direction of the load.

BIT	15~11	10	9	8	7	6	5	4	3	2	1	0
Value	0	Load Direction	Load Value									

Load Direction = 0 : CCW Load, Load Direction = 1: CW Load

Address 0x2A **Present Voltage.** The voltage currently applied to the Dynamixel actuator. The value is 10 times the actual voltage. For example, 10V is represented as 100 (0x64).

Address 0x2B **Present Temperature.** The internal temperature of the Dynamixel actuator in Degrees Celsius.

Address 0x2C **Registered Instruction.** Set to 1 when an instruction is assigned by the REG_WRITE command. Set to 0 after it completes the assigned instruction by the Action command.

Address 0x2E **Moving.** Set to 1 when the Dynamixel actuator is moving by its own power.

Address 0x2F **Lock.** If set to 1, only Address 0x18 to 0x23 can be written to and other areas cannot. Once locked, it can only be unlocked by turning the power off.

Address 0x30,0x31 **Punch.** The minimum current supplied to the motor during operation. The initial value is set to 0x20 and its maximum value is 0x3ff.

Endless Turn If both values for the CW Angle Limit and the CCW Angle Limit are set to 0, an Endless Turn mode can be implemented by setting the Goal Speed. This feature can be used for implementing a continuously rotating wheel.

Goal Speed Setting

BIT	15~11	10	9	8	7	6	5	4	3	2	1	0
Value	0	Turn Direction	Speed Value									

Turn Direction = 0 : CCW Direction Turn, Load Direction = 1: CW Direction Turn

Range

Each data has a valid minimum and maximum values. Write instructions made outside of these valid ranges will return an error. The following table summarizes the data range for each register. 16 bit data registers are indicated with two bytes (L) and (H). Both bytes need to be written at the same time as one instruction packet.

Write Address	Writing Item	Length (bytes)	Min	Max
3(0X03)	ID	1	0	253(0xfd)
4(0X04)	Baud Rate	1	0	254(0xfe)
5(0X05)	Return Delay Time	1	0	254(0xfe)
6(0X06)	CW Angle Limit	2	0	1023(0x3ff)
8(0X08)	CCW Angle Limit	2	0	1023(0x3ff)
11(0X0B)	the Highest Limit Temperature	1	0	150(0x96)
12(0X0C)	the Lowest Limit Voltage	1	50(0x32)	250(0xfa)
13(0X0D)	the Highest Limit Voltage	1	50(0x32)	250(0xfa)
14(0X0E)	Max Torque	2	0	1023(0x3ff)
16(0X10)	Status Return Level	1	0	2
17(0X11)	Alarm LED	1	0	127(0x7f)
18(0X12)	Alarm Shutdown	1	0	127(0x7f)
19(0X13)	(Reserved)	1	0	1
24(0X18)	Torque Enable	1	0	1
25(0X19)	LED	1	0	1
26(0X1A)	CW Compliance Margin	1	0	254(0xfe)
27(0X1B)	CCW Compliance Margin	1	0	254(0xfe)
28(0X1C)	CW Compliance Slope	1	1	254(0xfe)
29(0X1D)	CCW Compliance Slope	1	1	254(0xfe)
30(0X1E)	Goal Position	2	0	1023(0x3ff)
32(0X20)	Moving Speed	2	0	1023(0x3ff)
34(0X22)	Torque Limit	2	0	1023(0x3ff)
44(0X2C)	Registered Instruction	1	0	1
47(0X2F)	Lock	1	1	1
48(0X30)	Punch	2	0	1023(0x3ff)

[Control Table Data Range and Length for Writing]

4. Instruction Set and Examples

The following Instructions are available.

Instruction	Function	Value	Number of Parameter
PING	No action. Used for obtaining a Status Packet	0x01	0
READ DATA	Reading values in the Control Table	0x02	2
WRITE DATA	Writing values to the Control Table	0x03	2 ~
REG WRITE	Similar to WRITE_DATA, but stays in standby mode until the ACION instruction is given	0x04	2 ~
ACTION	Triggers the action registered by the REG_WRITE instruction	0x05	0
RESET	Changes the control table values of the Dynamixel actuator to the Factory Default Value settings	0x06	0
SYNC WRITE	Used for controlling many Dynamixel actuators at the same time	0x83	4~

4-1. WRITE_DATA

Function	To write data into the control table of the Dynamixel actuator
Length	N+3 (N is the number of data to be written)
Instruction	0X03
Parameter1	Starting address of the location where the data is to be written
Parameter2	1st data to be written
Parameter3	2nd data to be written
Parameter N+1	Nth data to be written

Example 1

Setting the ID of a connected Dynamixel actuator to 1

Write 1 to address 3 of the control table. The ID is transmitted using the Broadcasting ID (0xFE).

Instruction Packet : 0XFF 0XFF 0XFE 0X04 0X03 0X03 0X01 0XF6`

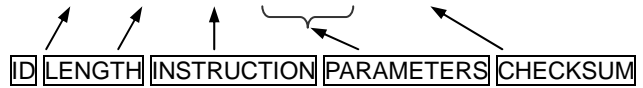

Because it was transmitted with a Broadcast ID (0XFE), no status packets are returned.

4-2. READ_DATA

Function	Read data from the control table of a Dynamixel actuator
Length	0X04
Instruction	0X02
Parameter1	Starting address of the location where the data is to be read
Parameter2	Length of the data to be read

Example 2

Reading the internal temperature of the Dynamixel actuator with an ID of 1

Read 1 byte from address 0x2B of the control table.

Instruction Packet : 0XFF 0XFF 0X01 0X04 0X02 0X2B 0X01 0XCC`

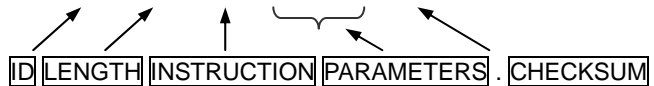

The returned Status Packet will be as the following.

Status Packet : 0XFF 0XFF 0X01 0X03 0X00 0X20 0XDB

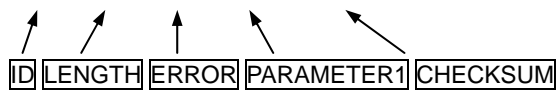

The data read is 0x20. Thus the current internal temperature of the Dynamixel actuator is approximately 32°C (0X20).

4-3. REG_WRITE ACTION

4-3-1. REG_WRITE

Function	The REG_WRITE instruction is similar to the WRITE_DATA instruction, but the execution timing is different. When the Instruction Packet is received the values are stored in the Buffer and the Write instruction is under a standby status. At this time, the Registered Instruction register (Address 0x2C) is set to 1. After the Action Instruction Packet is received, the registered Write instruction is finally executed.
Length	N+3 (N is the number of data to be written)
Instruction	0X04
Parameter1	Starting address of the location where the data is to be written
Parameter2	1st data to be written
Parameter3	2nd data to be written
Parameter N+1	Nth data to be written

4-3-2. ACTION

Function	Triggers the action registered by the REG_WRITE instruction
Length	0X02
Instruction	0X05
Parameter	NONE

The ACTION instruction is useful when multiple Dynamixel actuators need to move simultaneously. When controlling multiple Dynamixel actuator units, slight time delays can occur between the 1st and last units to receive an instruction. The Dynamixel actuator handles this problem by using the ACTION instruction.

Broadcasting	The Broadcast ID (0XFE) is used when sending ACTION instructions to more than two Dynamixel actuators. Note that no packets are returned by this operation.
---------------------	---

4-4. PING

Function	Does not command any operations. Used for requesting a status packet or to check the existence of a Dynamixel actuator with a specific ID.
Length	0X02
Instruction	0X01
Parameter	NONE

Example 3

Obtaining the status packet of the Dynamixel actuator with an ID of 1

Instruction Packet : 0XFF 0XFF 0X01 0X02 0X01 0XFB`

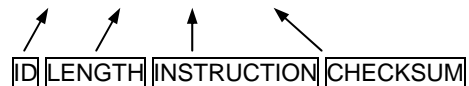

The returned Status Packet is as the following

Status Packet : 0XFF 0XFF 0X01 0X02 0X00 0XFC



Regardless of whether the Broadcasting ID is used or the Status Return Level (Address 16) is 0, a Status Packet is always returned by the PING instruction.

4-5. RESET

Function	Changes the control table values of the Dynamixel actuator to the Factory Default Value settings
Length	0X02
Instruction	0X06
Parameter	NONE

Example 4

Resetting the Dynamixel actuator with an ID of 0

Instruction Packet : 0XFF 0XFF 0X00 0X02 0X06 0XF7`

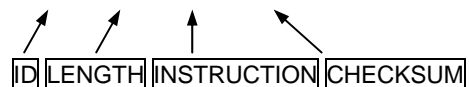

The returned Status Packet is as the following

Status Packet : 0XFF 0XFF 0X00 0X02 0X00 0XFD



Note the ID of this Dynamixel actuator is now changed to 1 after the RESET instruction.

4-6. SYNC WRITE

Function Used for controlling many Dynamixel actuators at the same time. The communication time decreases by the Synch Write instruction since many instructions can be transmitted by a single instruction. However, you can use this instruction only when the lengths and addresses of the control table to be written to are the same. Also, the broadcasting ID needs to be used for transmitting.

ID 0XFE

Length (L + 1) * N + 4 (L: Data length for each Dynamixel actuator, N: The number of Dynamixel actuators)

Instruction 0X83

Parameter1 Starting address of the location where the data is to be written

Parameter2 The length of the data to be written (L)

Parameter3 The ID of the 1st Dynamixel actuator

Parameter4 The 1st data for the 1st Dynamixel actuator

Parameter5 The 2nd data for the 1st Dynamixel actuator

...

Parameter L+3 The Lth data for the 1st Dynamixel actuator

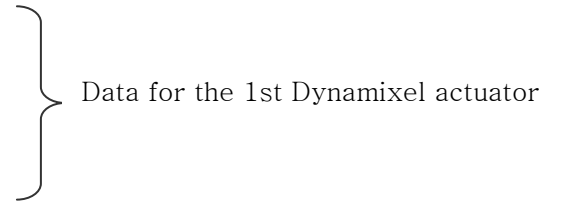

Parameter L+4 The ID of the 2nd Dynamixel actuator

Parameter L+5 The 1st data for the 2nd Dynamixel actuator

Parameter L+6 The 2nd data for the 2nd Dynamixel actuator

...

Parameter 2L+4 The Lth data for the 2nd Dynamixel actuator

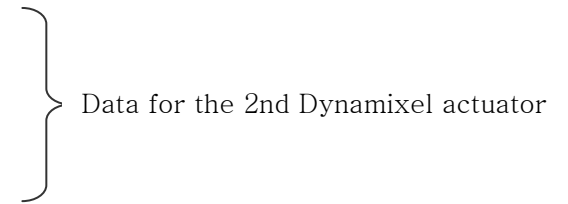

Example 5

Setting the following positions and velocities for 4 Dynamixel actuators

Dynamixel actuator with an ID of 0: to position 0X010 with a speed of 0X150

Dynamixel actuator with an ID of 1: to position 0X220 with a speed of 0X360

Dynamixel actuator with an ID of 2: to position 0X030 with a speed of 0X170

Dynamixel actuator with an ID of 0: to position 0X220 with a speed of 0X380

Instruction Packet : 0XFF 0XFF 0XFE 0X18 0X83 0X1E 0X04 0X00 0X10 0X00 0X50
0X01 0X01 0X20 0X02 0X60 0X03 0X02 0X30 0X00 0X70 0X01 0X03 0X20 0X02 0X80
0X03 0X12

No status packets are returned since the Broadcasting ID was used.

5. Example

For the following examples, we assume a Dynamixel actuator with an ID of 1 in Reset status and that the Baud rate is 57142 BPS.

Example 6

Reading the Model Number and Firmware Version of the Dynamixel actuator with an ID of 1

Instruction Packet Instruction = READ_DATA, Address = 0x00, Length = 0x03

Communication ->[Dynamixel]:FF FF 01 04 02 00 03 F5 (LEN:008)
<-[Dynamixel]:FF FF 01 05 00 1C 00 08 D5 (LEN:009)

Status Packet Result Model Number = 28 (0x1C) (for the case of RX-28) Firmware Version = 0x08

Example 7

Changing the ID to 0 for a Dynamixel actuator with an ID of 1

Instruction Packet Instruction = WRITE_DATA, Address = 0x03, DATA = 0x00

Communication ->[Dynamixel]:FF FF 01 04 03 03 00 F4 (LEN:008)
<-[Dynamixel]:FF FF 01 02 00 FC (LEN:006)

Status Packet Result NO ERROR

Example 8

Changing the Baud Rate of a Dynamixel actuator to 1M bps

Instruction Packet Instruction = WRITE_DATA, Address = 0x04, DATA = 0x01

Communication ->[Dynamixel]:FF FF 00 04 03 04 01 F3 (LEN:008)
<-[Dynamixel]:FF FF 00 02 00 FD (LEN:006)

Status Packet Result NO ERROR

Example 9

Resetting the Return Delay Time to 4 uSec for a Dynamixel actuator with an ID of 0

A Return Delay Time Value of 1 corresponds to 2uSec.

Instruction Packet Instruction = WRITE_DATA, Address = 0x05, DATA = 0x02

Communication ->[Dynamixel]:FF FF 00 04 03 05 02 F1 (LEN:008)
 <-[Dynamixel]:FF FF 00 02 00 FD (LEN:006)

Status Packet Result NO ERROR

It is recommended to set the Return Delay Time to the minimum value allowed by the Main Controller.

Example 10

Limiting the operating angle range to 0°~150° for a Dynamixel actuator with an ID of 0

Since the CCW Angle Limit of 0x3ff corresponds to 300°, the angle 150° is represented by the value 0x1ff

Instruction Packet Instruction = WRITE_DATA, Address = 0x08, DATA = 0xff, 0x01

Communication ->[Dynamixel]:FF FF 00 05 03 08 FF 01 EF (LEN:009)
 <-[Dynamixel]:FF FF 00 02 00 FD (LEN:006)

Status Packet Result NO ERROR

Example 11

Resetting the upper limit for the operating temperature to 80°C for a Dynamixel actuator with an ID of 0

Instruction Packet Instruction = WRITE_DATA, Address = 0x0B, DATA = 0x50

Communication ->[Dynamixel]:FF FF 00 04 03 0B 50 9D (LEN:008)
 <-[Dynamixel]:FF FF 00 02 00 FD (LEN:006)

Status Packet Result NO ERROR

Example 12

Setting the operating voltage to 10V ~ 17V for a Dynamixel actuator with an ID of 0

10V is represented by 100 (0x64), and 17V by 170 (0xAA).

Instruction Packet Instruction = WRITE_DATA, Address = 0x0C, DATA = 0x64, 0xAA

Communication ->[Dynamixel]:FF FF 00 05 03 0C 64 AA DD (LEN:009)
 <-[Dynamixel]:FF FF 00 02 00 FD (LEN:006)

Status Packet Result NO ERROR

Example 13**Setting the maximum torque to 50% of its maximum possible value for a Dynamixel actuator with an ID of 0**

Set the MAX Torque value located in the ROM area to 0x1ff which is 50% of the maximum value 0x3ff.

Instruction Packet Instruction = WRITE_DATA, Address = 0x0E, DATA = 0xff, 0x01

Communication ->[Dynamixel]:FF FF 00 05 03 0E FF 01 E9 (LEN:009)
 <-[Dynamixel]:FF FF 00 02 00 FD (LEN:006)

Status Packet Result NO ERROR

To verify the effect of the adjusted Max Torque value, the power needs to be turned off and then on.

Example 14**Set the Dynamixel actuator with an ID of 0 to never return a Status Packet**

Instruction Packet Instruction = WRITE_DATA, Address = 0x10, DATA = 0x00

Communication ->[Dynamixel]:FF FF 00 04 03 10 00 E8 (LEN:008)
 <-[Dynamixel]:FF FF 00 02 00 FD (LEN:006)

Status Packet Result NO ERROR

The Status Packet is not returned starting with the following instruction.

Example 15**Set the Alarm to blink the LED and Shutdown (Torque off) the actuator when the operating temperature goes over the set limit**

Since the Overheating Error is Bit 2, set the Alarm value to 0x04.

Instruction Packet Instruction = WRITE_DATA, Address = 0x11, DATA = 0x04, 0x04

Communication ->[Dynamixel]:FF FF 00 05 03 11 04 04 DE (LEN:009)
 <-[Dynamixel]:FF FF 00 02 00 FD (LEN:006)

Status Packet Result NO ERROR

Example 16**Turn on the LED and Enable Torque for a Dynamixel actuator with an ID of 0**

Instruction Packet Instruction = WRITE_DATA, Address = 0x18, DATA = 0x01, 0x01

Communication ->[Dynamixel]:FF FF 00 05 03 18 01 01 DD (LEN:009)
 <-[Dynamixel]:FF FF 00 02 00 FD (LEN:006)

Status Packet Result NO ERROR

You can verify the Torque Enabled status by trying to move the output of the actuator by hand.

Example 17

Setting the Compliance Margin to 1 and Compliance Slope to 0x40 for a Dynamixel actuator with an ID of 0

Compliance

The Angle Error and Torque Output can be represented with the following graph.

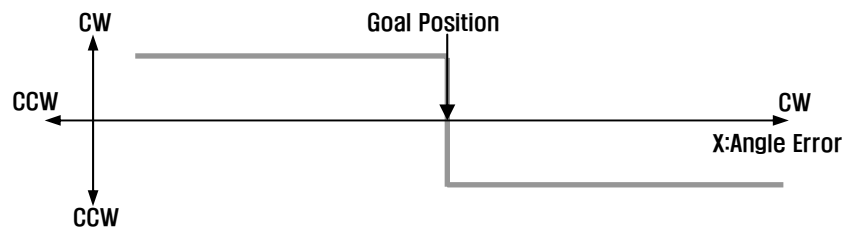

Even if the position deviates a little from the goal position in the CW direction, a large amount of torque is generated in the CCW direction to compensate for this. However, since inertia must be considered, a realistic implementation differs from this approach. Considering this, the given conditions can be represented by the following graph.

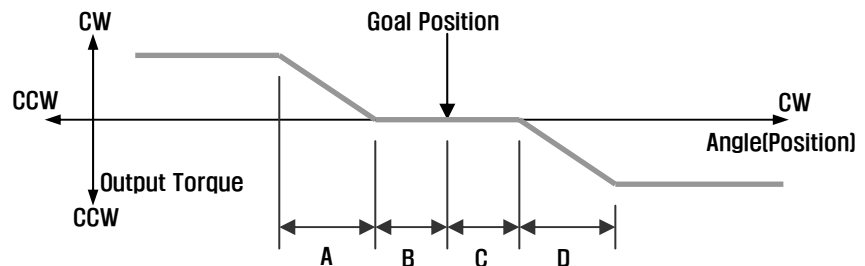

- A : CCW Compliance Slope (Address0x1D) = 0x40 (about 18.8°)
- B : CCW Compliance Margin (Address0x1B) = 0x01 (about 0.29°)
- C : CW Compliance Margin (Address0x01A) = 0x01 (about 0.29°)

Instruction Packet D : CW Compliance Slope (Address 0x1C) = 0x40 (about 18.8°)
 Instruction = WRITE_DATA, Address = 0x1A, DATA = 0x01, 0x01, 0x40, 0x40

Communication ->[Dynamixel]:FF FF 00 07 03 1A 01 01 40 40 59 (LEN:011)
 <-[Dynamixel]:FF FF 00 02 00 FD (LEN:006)

Status Packet Result NO ERROR
 The Compliance Slope takes effect with discrete steps of 2^n (n is integer). Thus any Compliance value between 0x11 and 0x20 has identical effects.

Example 18**Position the output of a Dynamixel actuator with an ID of 0 to 180° with an angular velocity of 057RPM**

Set Address 0x1E (Goal Position) to 0x200 and Address 0x20 (Moving Speed) to 0x200.

Instruction Packet Instruction = WRITE_DATA, Address = 0x1E, DATA = 0x00, 0x02, 0x00, 0x02

Communication ->[Dynamixel]:FF FF 00 07 03 1E 00 02 00 02 D3 (LEN:011)
 <-[Dynamixel]:FF FF 00 02 00 FD (LEN:006)

Status Packet Result NO ERROR

Example 19**Position the output of a Dynamixel actuator with an ID of 0 to 0° and Position the output of a Dynamixel actuator with an ID of 1 to 300°, and initiate the movement at the same time.**

If the WRITE_DATA is used, the movement of the two actuators cannot be initiated at the same time, thus the REG_WRITE and ACTION instructions should be used instead.

Instruction Packet ID=0, Instruction = REG_WRITE, Address = 0x1E, DATA = 0x00, 0x00
 ID=1, Instruction = REG_WRITE, Address = 0x1E, DATA = 0xff, 0x03
 ID=0xfe (Broadcasting ID), Instruction = ACTION,

Communication ->[Dynamixel]:FF FF 00 05 04 1E 00 00 D8 (LEN:009)
 <-[Dynamixel]:FF FF 00 02 00 FD (LEN:006)
 ->[Dynamixel]:FF FF 01 05 04 1E FF 03 D5 (LEN:009)
 <-[Dynamixel]:FF FF 01 02 00 FC (LEN:006)
 ->[Dynamixel]:FF FF FE 02 05 FA (LEN:006)
 <-[Dynamixel]: //No return packet against broadcasting ID

Status Packet Result NO ERROR

Example 20

Lock all addresses except for Address 0x18 ~ Address0x23 for a Dynamixel actuator with an ID of 0

Set Address 0x2F (Lock) to 1.

Instruction Packet Instruction = WRITE_DATA, Address = 0x2F, DATA = 0x01

Communication
->[Dynamixel]:FF FF 00 04 03 2F 01 C8 (LEN:008)
<-[Dynamixel]:FF FF 00 02 00 FD (LEN:006)

Status Packet Result NO ERROR

Once locked, the only way to unlock it is to remove the power.
If an attempt is made to access any locked data, an error is returned.

->[Dynamixel]:FF FF 00 05 03 30 40 00 87 (LEN:009)
<-[Dynamixel]:FF FF 00 02 08 F5 (LEN:006)

↖
Range Error

Example 21

Set the minimum power (Punch) to 0x40 for a Dynamixel actuator with an ID of 0

Instruction Packet Instruction = WRITE_DATA, Address = 0x30, DATA = 0x40, 0x00

Communication
->[Dynamixel]:FF FF 00 05 03 30 40 00 87 (LEN:009)
<-[Dynamixel]:FF FF 00 02 00 FD (LEN:006)

Status Packet Result NO ERROR

Appendix

RS485 UART

RS485 UART is a serial communication protocol where both TxD and RxD cannot be used at the same time. This method is generally used when many devices need to be connected to a single bus. Since more than one device are connected to the same bus, all the other devices need to be in input mode while one device is transmitting. The Main Controller that controls the Dynamixel actuators sets the communication direction to input mode, and only when it is transmitting an Instruction Packet, it changes the direction to output mode.

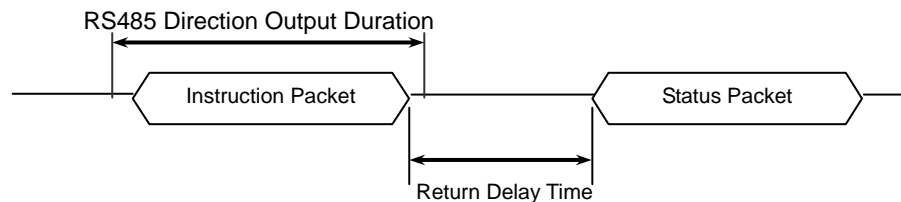

Return Delay Time

The time it takes for the Dynamixel actuator to return the Status Packet after receiving an Instruction Packet. The Default Value is 160 uSec and can be changed via the Control Table at Address 5. The Main Controller needs to change the Direction Port to input mode during the Return Delay Time after sending an instruction packet.

Tx,Rx Direction

For RS485 UART, the transmission ending timing is important to change the direction to receiving mode. The bit definitions within the register that indicates UART_STATUS are as the following

TXD_BUFFER_READY_BIT: Indicates that the transmission DATA can be loaded into the Buffer. Note that this only means that the SERIAL TX BUFFER is empty, and does not necessarily mean that the all the data transmitted before has left the CPU.

TXD_SHIFT_REGISTER_EMPTY_BIT: Set when all the Transmission Data has completed its transmission and left the CPU.

The TXD_BUFFER_READY_BIT is used when one byte is to be transmitted via the serial communication channel, and an example is shown below.

```
TxDByte(byte bData)
{
    while(!TXD_BUFFER_READY_BIT); //wait until data can be loaded.
    SerialTxDBuffer = bData;      //data load to TxD buffer
}
```

When changing the direction, the TXD_SHIFT_REGISTER_EMPTY_BIT must be checked.

The following is an example program that sends an Instruction Packet.

```

LINE 1      DIRECTION_PORT = TX_DIRECTION;
LINE 2      TxDByte(0xff);
LINE 3      TxDByte(0xff);
LINE 4      TxDByte(bID);
LINE 5      TxDByte(bLength);
LINE 6      TxDByte(bInstruction);
LINE 7      TxDByte(Parameter0); TxDByte(Parameter1); ...
LINE 8      DisableInterrupt(); // interrupt should be disable
LINE 9      TxDByte(Checksum); //last TxD
LINE 10     while(!TXD_SHIFT_REGISTER_EMPTY_BIT); //Wait till last data bit has been sent
LINE 11     DIRECTION_PORT = RX_DIRECTION; //Direction change to RXD
LINE 12     EnableInterrupt(); // enable interrupt again

```

Please note the important lines between LINE 8 and LINE 12. Line 8 is necessary since an interrupt here may cause a delay longer than the return delay time and corruption to the front of the status packet may occur.

Byte to Byte Time

The delay time between bytes when sending an instruction packet. If the delay time is over 100ms, then the Dynamixel actuator recognizes this as a communication problem and waits for the next header (0xff 0xff) of a packet again.

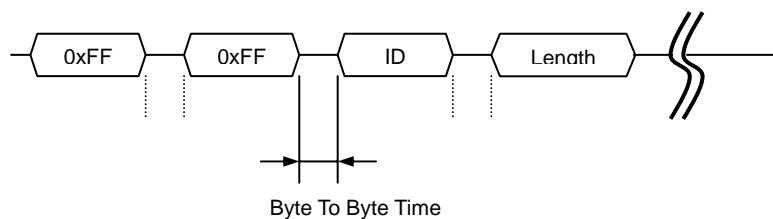

The following is the source code of a program (Example.c) that accesses the Dynamixel actuator using the Atmega 128.

C Language Example : Dinamixel access with Atmega128

```

/*
 * The Example of Dynamixel Evaluation with Atmega128
 * Date : 2005. 5. 11
 * Author : BS KIM
 */

/*
 * included files
 */
#define ENABLE_BIT_DEFINITIONS
#include <io.h>
#include <inttypes.h>
#include <avr/io.h>
#include <avr/interrupt.h>
#include <avr/signal.h>

#define cbi(REG8, BITNUM) REG8 &= ~(1<BITNUM>)
#define sbi(REG8, BITNUM) REG8 |= 1<BITNUM>

typedef unsigned char byte;
typedef unsigned int word;
#define ON 1
#define OFF 0
#define _ON 0
#define _OFF 1

//--- Control Table Address ---
//EEPROM AREA
#define P_MODEL_NUMBER_L 0
#define P_MODEL_NUMBER_H 1
#define P_VERSION 2
#define P_ID 3
#define P_BAUD_RATE 4
#define P_RETURN_DELAY_TIME 5
#define P_CW_ANGLE_LIMIT_L 6
#define P_CW_ANGLE_LIMIT_H 7
#define P_CCW_ANGLE_LIMIT_L 8
#define P_CCW_ANGLE_LIMIT_H 9
#define P_SYSTEM_DATA2 10
#define P_LIMIT_TEMPERATURE 11
#define P_DOWN_LIMIT_VOLTAGE 12
#define P_UP_LIMIT_VOLTAGE 13
#define P_MAX_TORQUE_L 14
#define P_MAX_TORQUE_H 15
#define P_RETURN_LEVEL 16
#define P_ALARM_LED 17
#define P_ALARM_SHUTDOWN 18
#define P_OPERATING_MODE 19
#define P_DOWN_CALIBRATION_L 20
#define P_DOWN_CALIBRATION_H 21
#define P_UP_CALIBRATION_L 22
#define P_UP_CALIBRATION_H 23

#define P_TORQUE_ENABLE (24)
#define P_LED (25)
#define P_CW_COMPLIANCE_MARGIN (26)
#define P_CCW_COMPLIANCE_MARGIN (27)
#define P_CW_COMPLIANCE_SLOPE (28)
#define P_CCW_COMPLIANCE_SLOPE (29)
#define P_GOAL_POSITION_L (30)
#define P_GOAL_POSITION_H (31)
#define P_GOAL_SPEED_L (32)
#define P_GOAL_SPEED_H (33)
#define P_TORQUE_LIMIT_L (34)
#define P_TORQUE_LIMIT_H (35)
#define P_PRESENT_POSITION_L (36)
#define P_PRESENT_POSITION_H (37)
#define P_PRESENT_SPEED_L (38)
#define P_PRESENT_SPEED_H (39)
#define P_PRESENT_LOAD_L (40)
#define P_PRESENT_LOAD_H (41)
#define P_PRESENT_VOLTAGE (42)
#define P_PRESENT_TEMPERATURE (43)

```

```

#define P_REGISTERED_INSTRUCTION (44)
#define P_PAUSE_TIME (45)
#define P_MOVING (46)
#define P_LOCK (47)
#define P_PUNCH_L (48)
#define P_PUNCH_H (49)

//--- Instruction ---
#define INST_PING 0x01
#define INST_READ 0x02
#define INST_WRITE 0x03
#define INST_REG_WRITE 0x04
#define INST_ACTION 0x05
#define INST_RESET 0x06
#define INST_DIGITAL_RESET 0x07
#define INST_SYSTEM_READ 0x0C
#define INST_SYSTEM_WRITE 0x0D
#define INST_SYNC_WRITE 0x83
#define INST_SYNC_REG_WRITE 0x84

#define CLEAR_BUFFER gbRxBufferReadPointer = gbRxBufferWritePointer
#define DEFAULT_RETURN_PACKET_SIZE 6
#define BROADCASTING_ID 0xfe

#define TxD8 TxDB1
#define RxDB8 RxDB1

//Hardware Dependent Item
#define DEFAULT_BAUD_RATE 34 //57600bps at 16MHz

////// For CM-2 PLUS
#define RS485_TXD PORTE &= ~_BV(PE3), PORTE |= _BV(PE2)
//PORT_485_DIRECTION = 1
#define RS485_RXD PORTE &= ~_BV(PE2), PORTE |= _BV(PE3)
//PORT_485_DIRECTION = 0

/*
////// For CM-2
#define RS485_TXD PORTE |= _BV(PE2); //PORT_485_DIRECTION = 1
#define RS485_RXD PORTE &= ~_BV(PE2); //PORT_485_DIRECTION = 0
*/
//#define TXD0_FINISH UCSROA, 6 //This bit is for checking TxD Buffer
//in CPU is empty or not.
//#define TXD1_FINISH UCSR1A, 6

#define SET_TXD0_FINISH sbi(UCSROA, 6)
#define RESET_TXD0_FINISH cbi(UCSROA, 6)
#define CHECK_TXD0_FINISH bit_is_set(UCSROA, 6)
#define SET_TXD1_FINISH sbi(UCSR1A, 6)
#define RESET_TXD1_FINISH cbi(UCSR1A, 6)
#define CHECK_TXD1_FINISH bit_is_set(UCSR1A, 6)

#define RX_INTERRUPT 0x01
#define TX_INTERRUPT 0x02
#define OVERFLOW_INTERRUPT 0x01
#define SERIAL_PORT0 0
#define SERIAL_PORT1 1
#define BIT_RS485_DIRECTION0 0x08 //Port E
#define BIT_RS485_DIRECTION1 0x04 //Port E

#define BIT_ZIGBEE_RESET PD4 //out : default 1 //PORTD
#define BIT_ENABLE_RXD_LINK_PC PD5 //out : default 1
#define BIT_ENABLE_RXD_LINK_ZIGBEE PD6 //out : default 0
#define BIT_LINK_PLUGIN PD7 //in, no pull up

void TxDB1(byte bTxData);
void TxDB0(byte bTxData);
void TxDString(byte *bData);
void TxDBHex(byte bSentData);
void TxD32Dec(long lLong);
byte RxDB1(void);
void MilliSec(word wDelayTime);
void PortInitialize(void);
void SerialInitialize(byte bPort, byte bBaudrate, byte bInterrupt);
byte TxPacket(byte bID, byte bInstruction, byte bParameterLength);
byte RxPacket(byte bRxLength);
void PrintBuffer(byte *bpPrintBuffer, byte bLength);

```

```

// --- Global Variable Number ---
volatile byte gbpRxInterruptBuffer[256];
byte gbpParameter[128];
byte gbRxBufferReadPointer;
byte gbpRxBuffer[128];
byte gbpTxBuffer[128];
volatile byte gbRxBufferWritePointer;

int main(void)
{
    byte bCount, bID, bTxPacketLength, bRxPacketLength;

    PortInitialize(); //Port In/Out Direction Definition
    RS485_RXD; //Set RS485 Direction to Input State.
    SerialInitialize(SERIAL_PORT0, 1, RX_INTERRUPT); //RS485
        Initializing(RxInterrupt)
    SerialInitialize(SERIAL_PORT1, DEFAULT_BAUD_RATE, 0); //RS232
        Initializing(None Interrupt)

    gbRxBufferReadPointer = gbRxBufferWritePointer = 0; //RS485
        RxBuffer Clearing.

    sei(); //Enable Interrupt --- Compiler Function
    TxDString("Rn Example of Dynamixel Evaluation with
        ATmega128, GCC-AVR");

    //Dynamixel Communication Function Execution Step.
    // Step 1. Parameter Setting (gbpParameter[]). In case of no parameter
        instruction(Ex. INST_PING), this step is not
        needed.
    // Step 2. TxPacket(ID, INSTRUCTION, LengthOfParameter); ---Total
        TxPacket Length is returned
    // Step 3. RxPacket(ExpectedReturnPacketLength); --- Real RxPacket
        Length is returned
    // Step 4 PrintBuffer(BufferStartPointer, LengthForPrinting);

    bID = 1;
    TxDString("Rn Example 1. Scanning Dynamixels(0~9). --- Any Key to
        Continue."); RxD8();
    for (bCount = 0; bCount < 0x0A; bCount++)
    {
        bTxPacketLength = TxPacket(bCount, INST_PING, 0);
        bRxPacketLength = RxPacket(255);
        TxDString("Rn TxD:"); PrintBuffer(gbpTxBuffer, bTxPacketLength);
        TxDString("Rn RxD:"); PrintBuffer(gbpRxBuffer, bRxPacketLength);
        if (bRxPacketLength == DEFAULT_RETURN_PACKET_SIZE)
        {
            TxDString(" Found!! ID:"); TxD8Hex(bCount);
            bID = bCount;
        }
    }

    TxDString("Rn Example 2. Read Firmware Version. --- Any Key to
        Continue."); RxD8();
    gbpParameter[0] = P_VERSION; //Address of Firmware Version
    gbpParameter[1] = 1; //Read Length
    bTxPacketLength = TxPacket(bID, INST_READ, 2);
    bRxPacketLength = RxPacket(DEFAULT_RETURN_PACKET_SIZE+gbpParameter
        [1]);
    TxDString("Rn TxD:"); PrintBuffer(gbpTxBuffer, bTxPacketLength);
    TxDString("Rn RxD:"); PrintBuffer(gbpRxBuffer, bRxPacketLength);
    if (bRxPacketLength == DEFAULT_RETURN_PACKET_SIZE+gbpParameter[1])
    {
        TxDString("Rn Return Error :"); TxD8Hex(gbpRxBuffer[4]);
        TxDString("Rn Firmware Version :"); TxD8Hex(gbpRxBuffer[5]);
    }

    TxDString("Rn Example 3. LED ON --- Any Key to Continue.");
        RxD8();
    gbpParameter[0] = P_LED; //Address of LED
    gbpParameter[1] = 1; //Writing Data
    bTxPacketLength = TxPacket(bID, INST_WRITE, 2);
    bRxPacketLength = RxPacket(DEFAULT_RETURN_PACKET_SIZE);
    TxDString("Rn TxD:"); PrintBuffer(gbpTxBuffer, bTxPacketLength);
    TxDString("Rn RxD:"); PrintBuffer(gbpRxBuffer, bRxPacketLength);

```

```

    TxDString("Rn Example 4. LED OFF --- Any Key to Continue.");
        RxD8();
    gbpParameter[0] = P_LED; //Address of LED
    gbpParameter[1] = 0; //Writing Data
    bTxPacketLength = TxPacket(bID, INST_WRITE, 2);
    bRxPacketLength = RxPacket(DEFAULT_RETURN_PACKET_SIZE);
    TxDString("Rn TxD:"); PrintBuffer(gbpTxBuffer, bTxPacketLength);
    TxDString("Rn RxD:"); PrintBuffer(gbpRxBuffer, bRxPacketLength);

    TxDString("Rn Example 5. Read Control Table. --- Any Key to
        Continue."); RxD8();
    gbpParameter[0] = 0; //Reading Address
    gbpParameter[1] = 49; //Read Length
    bTxPacketLength = TxPacket(bID, INST_READ, 2);
    bRxPacketLength = RxPacket(DEFAULT_RETURN_PACKET_SIZE+gbpParameter
        [1]);

    TxDString("Rn TxD:"); PrintBuffer(gbpTxBuffer, bTxPacketLength);
    TxDString("Rn RxD:"); PrintBuffer(gbpRxBuffer, bRxPacketLength);
    if (bRxPacketLength == DEFAULT_RETURN_PACKET_SIZE+gbpParameter[1])
    {
        TxDString("Rn");
        for (bCount = 0; bCount < 49; bCount++)
        {
            TxD8(' '); TxD8Hex(bCount); TxDString(" ");
            TxD8Hex(gbpRxBuffer[bCount+5]); TxD8(' ');
        }
    }

    TxDString("Rn Example 6. Go 0x200 with Speed 0x100 --- Any Key to
        Continue."); RxD8();
    gbpParameter[0] = P_GOAL_POSITION_L; //Address of Firmware Version
    gbpParameter[1] = 0x00; //Writing Data P_GOAL_POSITION_L
    gbpParameter[2] = 0x02; //Writing Data P_GOAL_POSITION_H
    gbpParameter[3] = 0x00; //Writing Data P_GOAL_SPEED_L
    gbpParameter[4] = 0x01; //Writing Data P_GOAL_SPEED_H
    bTxPacketLength = TxPacket(bID, INST_WRITE, 5);
    bRxPacketLength = RxPacket(DEFAULT_RETURN_PACKET_SIZE);
    TxDString("Rn TxD:"); PrintBuffer(gbpTxBuffer, bTxPacketLength);
    TxDString("Rn RxD:"); PrintBuffer(gbpRxBuffer, bRxPacketLength);

    TxDString("Rn Example 7. Go 0x00 with Speed 0x40 --- Any Key to
        Continue."); RxD8();
    gbpParameter[0] = P_GOAL_POSITION_L; //Address of Firmware Version
    gbpParameter[1] = 0x00; //Writing Data P_GOAL_POSITION_L
    gbpParameter[2] = 0x00; //Writing Data P_GOAL_POSITION_H
    gbpParameter[3] = 0x40; //Writing Data P_GOAL_SPEED_L
    gbpParameter[4] = 0x00; //Writing Data P_GOAL_SPEED_H
    bTxPacketLength = TxPacket(bID, INST_WRITE, 5);
    bRxPacketLength = RxPacket(DEFAULT_RETURN_PACKET_SIZE);
    TxDString("Rn TxD:"); PrintBuffer(gbpTxBuffer, bTxPacketLength);
    TxDString("Rn RxD:"); PrintBuffer(gbpRxBuffer, bRxPacketLength);

    TxDString("Rn Example 8. Go 0x3ff with Speed 0x3ff --- Any Key to
        Continue."); RxD8();
    gbpParameter[0] = P_GOAL_POSITION_L; //Address of Firmware Version
    gbpParameter[1] = 0xff; //Writing Data P_GOAL_POSITION_L
    gbpParameter[2] = 0x03; //Writing Data P_GOAL_POSITION_H
    gbpParameter[3] = 0xff; //Writing Data P_GOAL_SPEED_L
    gbpParameter[4] = 0x03; //Writing Data P_GOAL_SPEED_H
    bTxPacketLength = TxPacket(bID, INST_WRITE, 5);
    bRxPacketLength = RxPacket(DEFAULT_RETURN_PACKET_SIZE);
    TxDString("Rn TxD:"); PrintBuffer(gbpTxBuffer, bTxPacketLength);
    TxDString("Rn RxD:"); PrintBuffer(gbpRxBuffer, bRxPacketLength);

    TxDString("Rn Example 9. Torque Off --- Any Key to Continue.");
        RxD8();
    gbpParameter[0] = P_TORQUE_ENABLE; //Address of LED
    gbpParameter[1] = 0; //Writing Data
    bTxPacketLength = TxPacket(bID, INST_WRITE, 2);
    bRxPacketLength = RxPacket(DEFAULT_RETURN_PACKET_SIZE);
    TxDString("Rn TxD:"); PrintBuffer(gbpTxBuffer, bTxPacketLength);
    TxDString("Rn RxD:"); PrintBuffer(gbpRxBuffer, bRxPacketLength);

    TxDString("Rn End. Push reset button for repeat");

```

```

while(1);
}

void PortInitialize(void)
{
  DDRA = DDRB = DDRC = DDRD = DDRE = DDRF = 0; //Set all port to
  input direction first.
  PORTB = PORTC = PORTD = PORTE = PORTF = PORTG = 0x00; //PortData
  initialize to 0
  cbi(SFIOR, 2); //All Port Pull Up ready
  DDRE |= (BIT_RS485_DIRECTION0|BIT_RS485_DIRECTION1); //set output
  the bit RS485direction

  DDRD                                     |=
  (BIT_ZIGBEE_RESET|BIT_ENABLE_RXD_LINK_PC|BIT_ENA
  BLE_RXD_LINK_ZIGBEE);

  PORTD &= ~_BV(BIT_LINK_PLUGIN); // no pull up
  PORTD |= _BV(BIT_ZIGBEE_RESET);
  PORTD |= _BV(BIT_ENABLE_RXD_LINK_PC);
  PORTD |= _BV(BIT_ENABLE_RXD_LINK_ZIGBEE);
}

/*
TxPacket() send data to RS485.
TxPacket() needs 3 parameter: ID of Dynamixel, Instruction byte,
Length of parameters.
TxPacket() return length of Return packet from Dynamixel.
*/
byte TxPacket(byte bID, byte bInstruction, byte bParameterLength)
{
  byte bCount, bChecksum, bPacketLength;

  gbpTxBuffer[0] = 0xff;
  gbpTxBuffer[1] = 0xff;
  gbpTxBuffer[2] = bID;
  gbpTxBuffer[3] = bParameterLength+2;
  //Length(Paramter, Instruction, Checksum)
  gbpTxBuffer[4] = bInstruction;
  for(bCount = 0; bCount < bParameterLength; bCount++)
  {
    gbpTxBuffer[bCount+5] = gbpParameter[bCount];
  }
  bChecksum = 0;
  bPacketLength = bParameterLength+4+2;
  for(bCount = 2; bCount < bPacketLength-1; bCount++) //except
  0xff, checksum
  {
    bChecksum += gbpTxBuffer[bCount];
  }
  gbpTxBuffer[bCount] = ~bChecksum; //Writing Checksum with Bit
  Inversion

  RS485_TXD;
  for(bCount = 0; bCount < bPacketLength; bCount++)
  {
    sbi(UCSR0A, 6); //SET_TXD0_FINISH;
    TxD80(gbpTxBuffer[bCount]);
  }
  while(!CHECK_TXD0_FINISH); //Wait until TXD Shift register empty
  RS485_RXD;
  return(bPacketLength);
}

/*
RxPacket() read data from buffer.
RxPacket() need a Parameter: Total length of Return Packet.
RxPacket() return Length of Return Packet.
*/
byte RxPacket(byte bRxPacketLength)
{
#define RX_TIMEOUT_COUNT2 3000L
#define RX_TIMEOUT_COUNT1 (RX_TIMEOUT_COUNT2*10L)
  unsigned long ulCounter;
  byte bCount, bLength, bChecksum;
  byte bTimeout;

```

```

  bTimeout = 0;
  for(bCount = 0; bCount < bRxPacketLength; bCount++)
  {
    ulCounter = 0;
    while(gbRxBufferReadPointer == gbRxBufferWritePointer)
    {
      if(ulCounter++ > RX_TIMEOUT_COUNT1)
      {
        bTimeout = 1;
        break;
      }
    }
    if(bTimeout) break;
    gbpRxBuffer[bCount] = gbRxInterruptBuffer[gbRxBufferReadPointer++];
  }
  bLength = bCount;
  bChecksum = 0;

  if(gbpTxBuffer[2] != BROADCASTING_ID)
  {
    if(bTimeout && bRxPacketLength != 255)
    {
      TxDString("%r\n [Error:Rx Timeout]");
      CLEAR_BUFFER;
    }
  }

  if(bLength > 3) //checking is available.
  {
    if(gbpRxBuffer[0] != 0xff || gbpRxBuffer[1] != 0xff)
    {
      TxDString("%r\n [Error:Wrong Header]");
      CLEAR_BUFFER;
      return 0;
    }
    if(gbpRxBuffer[2] != gbpTxBuffer[2])
    {
      TxDString("%r\n [Error:TxID != RxID]");
      CLEAR_BUFFER;
      return 0;
    }
    if(gbpRxBuffer[3] != bLength-4)
    {
      TxDString("%r\n [Error:Wrong Length]");
      CLEAR_BUFFER;
      return 0;
    }
    for(bCount = 2; bCount < bLength; bCount++) bChecksum +=
    gbpRxBuffer[bCount];
    if(bChecksum != 0xff)
    {
      TxDString("%r\n [Error:Wrong CheckSum]");
      CLEAR_BUFFER;
      return 0;
    }
  }
  return bLength;
}

/*
PrintBuffer() print data in Hex code.
PrintBuffer() needs two parameter: name of Pointer(gbpTxBuffer,
gbpRxBuffer)
*/
void PrintBuffer(byte *bpPrintBuffer, byte bLength)
{
  byte bCount;
  for(bCount = 0; bCount < bLength; bCount++)
  {
    TxD8Hex(bpPrintBuffer[bCount]);
    TxD8(' ');
  }
  TxDString("(LEN:"); TxD8Hex(bLength); TxD8(')');
}

```

```

/*
Print value of Baud Rate.
*/
void PrintBaudrate(void)
{
  TxDString("%r\n
            RS232:");TxD32Dec((1600000L/8L)/((long)UBRR1L+1
L)); TxDString(" BPS,");
  TxDString(" RS485:");TxD32Dec((1600000L/8L)/((long)UBRR0L+1L) );
  TxDString(" BPS");
}

/*Hardware Dependent Item*/
#define TXD1_READY          bit_is_set(UCSR1A, 5)
                          //(UCSR1A_Bit5)
#define TXD1_DATA          (UDR1)
#define RXD1_READY        bit_is_set(UCSR1A, 7)
#define RXD1_DATA          (UDR1)

#define TXD0_READY        bit_is_set(UCSR0A, 5)
#define TXD0_DATA          (UDR0)
#define RXD0_READY        bit_is_set(UCSR0A, 7)
#define RXD0_DATA          (UDR0)

/*
SerialInitialize() set Serial Port to initial state.
Vide Mega128 Data sheet about Setting bit of register.
SerialInitialize() needs port, Baud rate, Interrupt value.
*/
void SerialInitialize(byte bPort, byte bBaudrate, byte bInterrupt)
{
  if(bPort == SERIAL_PORT0)
  {
    UBRR0H = 0; UBRR0L = bBaudrate;
    UCSROA = 0x02; UCSROB = 0x18;
    if(bInterrupt&RX_INTERRUPT) sbi(UCSR0B, 7); // RxD interrupt enable
    UCSROC = 0x06; UDRO = 0xFF;
    sbi(UCSR0A, 6);//SET_TXD0_FINISH; // Note. set 1, then 0 is read
  }
  else if(bPort == SERIAL_PORT1)
  {
    UBRR1H = 0; UBRR1L = bBaudrate;
    UCSR1A = 0x02; UCSR1B = 0x18;
    if(bInterrupt&RX_INTERRUPT) sbi(UCSR1B, 7); // RxD interrupt enable
    UCSR1C = 0x06; UDR1 = 0xFF;
    sbi(UCSR1A, 6);//SET_TXD1_FINISH; // Note. set 1, then 0 is read
  }
}

/*
TxD8Hex() print data seperatly.
ex> 0x1a -> '1' 'a'.
*/
void TxD8Hex(byte bSentData)
{
  byte bTmp;

  bTmp =((byte) (bSentData>>4) &0x0f) + (byte)'0';
  if(bTmp > '9') bTmp += 7;
  TxD8(bTmp);
  bTmp = (byte) (bSentData & 0x0f) + (byte)'0';
  if(bTmp > '9') bTmp += 7;
  TxD8(bTmp);
}

/*
TxD80() send data to USART 0.
*/
void TxD80(byte bTxdData)
{
  while(!TXD0_READY);
  TXD0_DATA = bTxdData;
}

}

/*
TxD81() send data to USART 1.
*/
void TxD81(byte bTxdData)
{
  while(!TXD1_READY);
  TXD1_DATA = bTxdData;
}

/*
TXD32Dex() change data to decimal number system
*/
void TxD32Dec(long lLong)
{
  byte bCount, bPrinted;
  long lTmp, lDigit;
  bPrinted = 0;
  if(lLong < 0)
  {
    lLong = -lLong;
    TxD8('-');
  }
  lDigit = 1000000000L;
  for(bCount = 0; bCount < 9; bCount++)
  {
    lTmp = (byte) (lLong/lDigit);
    if(lTmp)
    {
      TxD8(((byte)lTmp)+'0');
      bPrinted = 1;
    }
    else if(bPrinted) TxD8(((byte)lTmp)+'0');
    lLong -= ((long)lTmp)*lDigit;
    lDigit = lDigit/10;
  }
  lTmp = (byte) (lLong/lDigit);
  /*if(lTmp)*/ TxD8(((byte)lTmp)+'0');
}

/*
TxDString() prints data in ACSII code.
*/
void TxDString(byte *bData)
{
  while(*bData)
  {
    TxD8(*bData++);
  }
}

/*
RxD81() read data from UART1.
RxD81() return Read data.
*/
byte RxD81(void)
{
  while(!RXD1_READY);
  return(RXD1_DATA);
}

/*
SIGNAL() UART0 Rx Interrupt - write data to buffer
*/
SIGNAL (SIG_UART0_RECVC)
{
  gbpRxInterruptBuffer[(gbRxBufferWritePointer++)] = RXD0_DATA;
}

```

Connector

Company Name : Molex

Pin Number: 4 (or 5 for Optional VCC 5V)

Model Number

	Molex Part Number	Old Part Number
Male	22-03-5045	5267-04
Female	50-37-5043	5264-04

Temperature range : -40°C to +105°C

Contact Insertion Force-max : 14.7N (3.30 lb)

Contact Retention Force-min : 14.7N (3.30 lb)

www.molex.com or www.molex.co.jp for more detail information

Female Connector

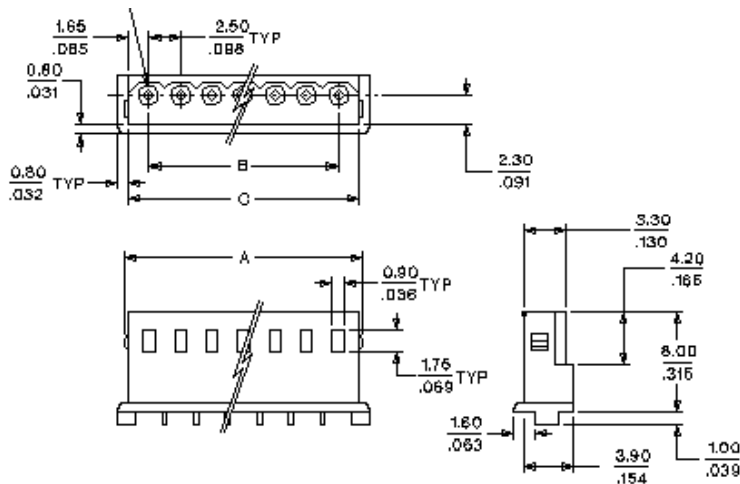

Male Connector

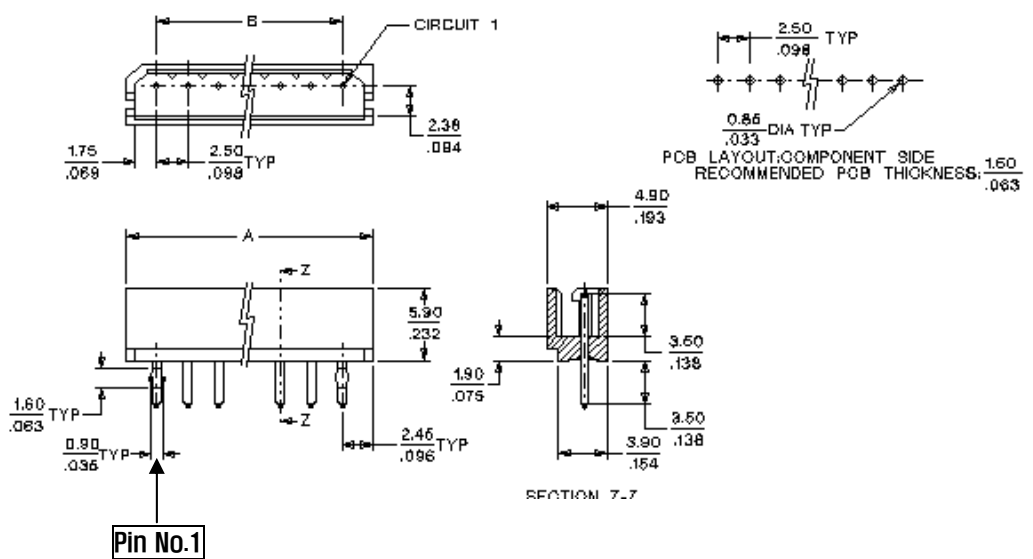

Dimension

